

# iTECHBM500 USER GUIDE

## iTECHBM500 BATTERY MONITOR WITH 500A SHUNT

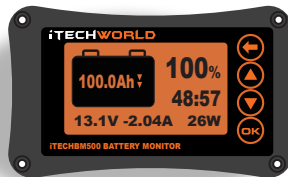

Thank you for choosing our battery monitor! We appreciate your purchase and trust in our product. Please take the time to read through the manual in detail before installing and using it. If you have any questions or need assistance regarding safety precautions, installation, or usage, please feel free to contact us using the contact details below.

### Product Introduction:

The iTECHBM500 is a high-precision battery monitor that captures instantaneous and integrated values in real-time. The iTECHBM500 utilizes 500A current shunt, the iTECHBM500 measures the discharge/ recharge currents and calculate the Ampere-hours (Ah) going in and out of the battery. The monitor provides real-time, high-precision voltage measurements through a field-installed sense wire. It is compatible with Lithium-ion, lead-acid, and nickel-metal hydride batteries.

### Applications:

Golf Carts & Utility Vehicles  
Caravan & RV's  
Marine & Boats  
4WD & Canopy Setups  
Battery Systems  
Solar Energy Storage

### Data Displayed:

Battery Capacity  
Battery Voltage  
Battery Current  
Battery State of Charge (SOC)  
Charge-Discharge indicator  
Remaining Time

**iTECHWORLD**

Parameter	Min	Max	Unit
Voltage	10.0	80.0	V
Current	0.0	500.0	A
Capacity	0.1	9999.0	Ah
Temperature	-10	60	°C
Backlight on Current	200	400.0	mA
Voltage Accuracy	±1		%
Current Accuracy	±1		%
Capacity Accuracy	±1		%

### Included Components: Additional Components Needed For Installation:

- iTECHBM500 (Display)
- 500A Current shunt
- Shielded wire (8M)
- B+ Sense wire 22AWG (1M)
- 4 screws
- Shunt holder
- Additional battery cable
- Knock out tool
- 1 A fuse

### Battery Display:

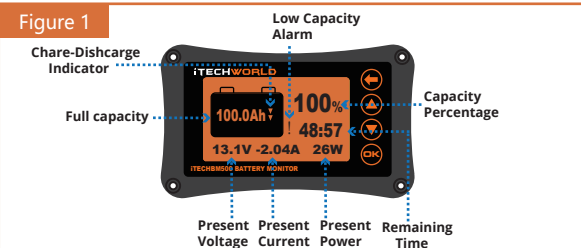

### Dimensions:

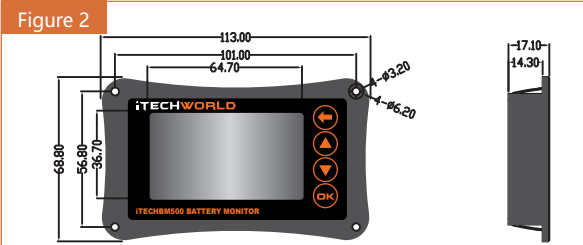

### Monitor Display Installation:

1. Use a Jigsaw to cut a hole in the surface on which the battery monitor is to be mounted. Then put the iTECHBM500 battery monitor into the rectangular orifice, and make sure the tabs are locked.
2. If the tabs can not be locked, then use the 4 screw holes to attach the monitor from the front of the hole.

### Rear Mount

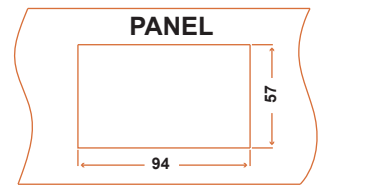

### Screw Position-Front Mount

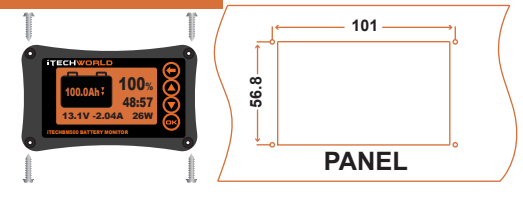

### Electrical Connections:

1. Before doing anything, disconnect all wires from the negative side of the battery
2. Cut the negative cable for the battery and crimp on new ring terminals. Alternatively, use a new wire of appropriate gauge to carry the full current demand of the system
3. Connect the shunt as show in the wiring diagram(Figure 3)  
Note: The negative terminal of the battery must connect directly to the B- side of the shunt and there should be no connections to the negative terminal of the battery
4. Using the sense wire, connect the ring terminal end of the wire to positive of battery. The other end connects to B+ of shunt.  
Note: Do not stack smaller terminals under large ones.
5. Connect the shunt to the BM500 using the shielded wire to test. If done correctly the display will turn on. Disconnect again so remote display can be mounted.

Figure 3 Connection diagram of 500A shunt

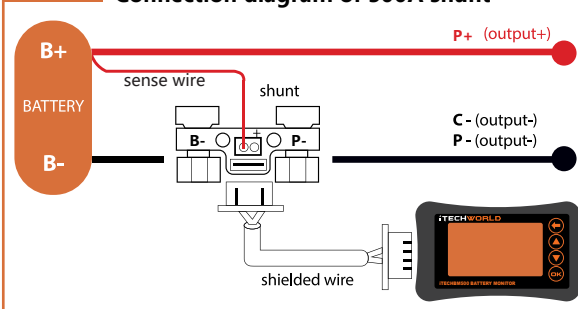

### Preparation Steps:

Fully charge the battery bank such that it reaches 100% SOC. Failure to take this step will lead to erroneous SOC readings.

### Setting Up The Battery Monitor:

1. Ensure the battery display indicates the discharge current and the charge current correctly. Use the charge and discharge indicators to ensure it is capturing the appropriate current direction (in/out).
2. Ensure that the battery voltage is displayed correctly.
3. Fully charge the battery bank such that it reaches 100% SOC.
4. To initialize the capacity, press the Ⓢ button for three seconds to set the capacity to 100%
5. To enter the setting menu, press the OK button for 3s.
6. Click Ⓢ or Ⓣ button to select the setting items.



For example, select CAP and click the OK button to enter the pre-set capacity setting. The set value will flicker, click Ⓢ or Ⓣ button to increase or decrease the capacity, clicking the OK button can select other values. After this click the Ⓢ button to quit pre-se capacity setting.

7. The "High V" and "Low V" parameters in the settings screen are for automatic state of charge synchronization. If the battery voltage is above "High V" the state of charge will reset to 100% and if it falls below "Low V" the state of charge will reset to 0%. Setting either of these values to zero will disable this function.  
Note: Generally the High/ Low V do not need to be setted. The default of High V is 0V, Low V is 0V, which is the invalid. If you want to set, please understand the actual charge and discharge voltage of battery firstly.
8. Lower battery capacity limit in ampere-hours. If the battery is discharged below this limit and audible alarm will sound. Setting this value to zero will disable this function.
9. The iTECHBM500 will go into a sleep mode if the battery current drops below 300mA. To wake it from this mode, press any key. The screen will automatically wake once the battery starts charging or discharging.  
Turn off backlight - To turn off the backlight, long press Ⓢ to turn off the backlight, long press Ⓢ again to wake up the backlight.  
Click Ⓢ or Ⓣ button to increase or decrease backlight Brightness. Ⓢ 0~10 level.

**Technical Support:** If you have any technical questions about your iTECHBM500 monitor, please visit the iTechworld help centre which can be found at [www.itechworld.com.au](http://www.itechworld.com.au) or contact us [service@itechworld.com.au](mailto:service@itechworld.com.au).

**Warranty:** One-year limited warranty.

**iTECHWORLD**